

A

B

C

D

E

F

A

B

C

D

E

F

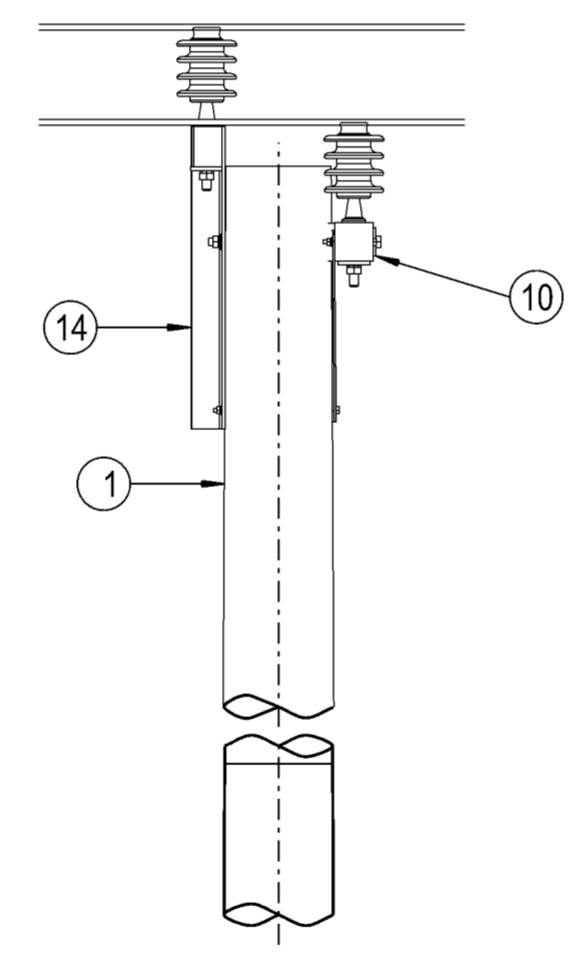
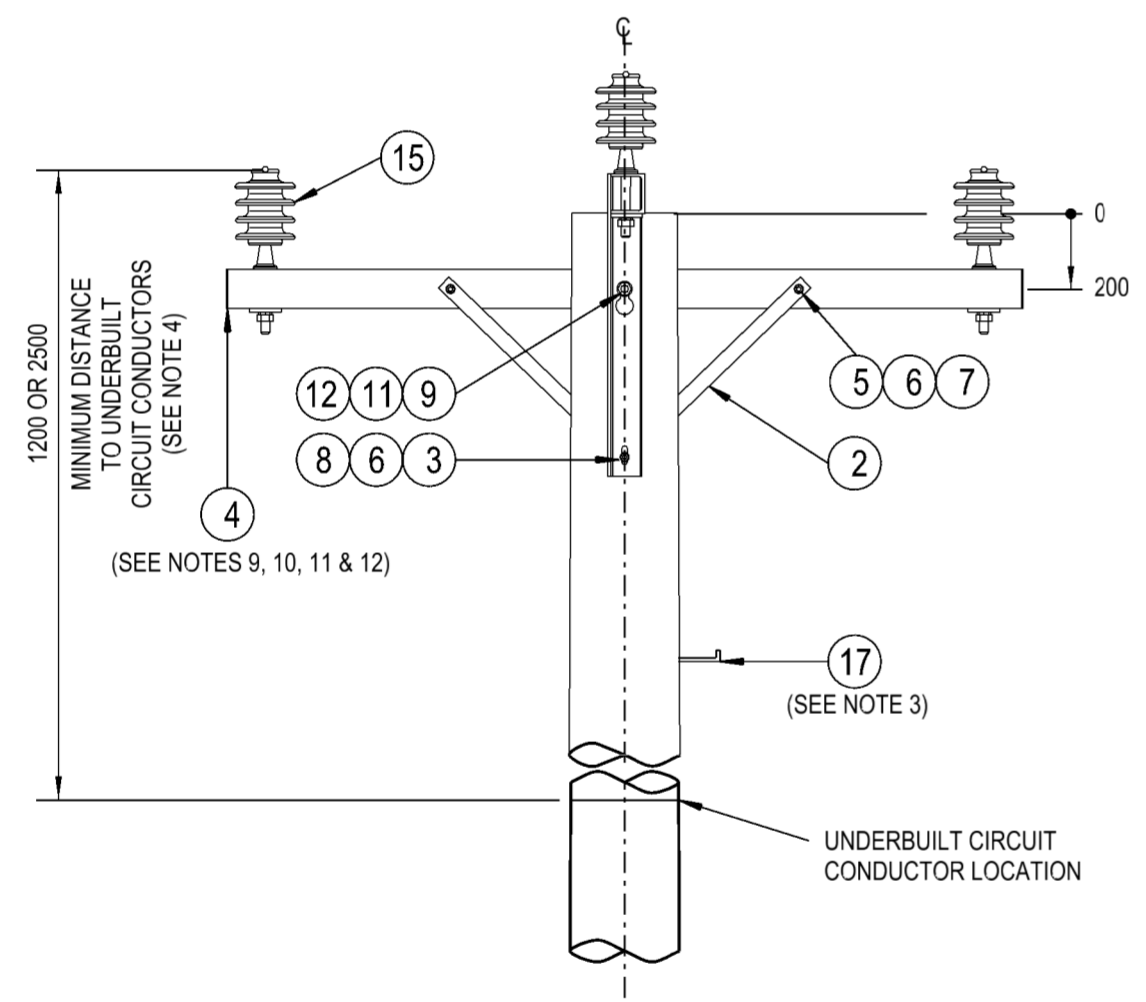
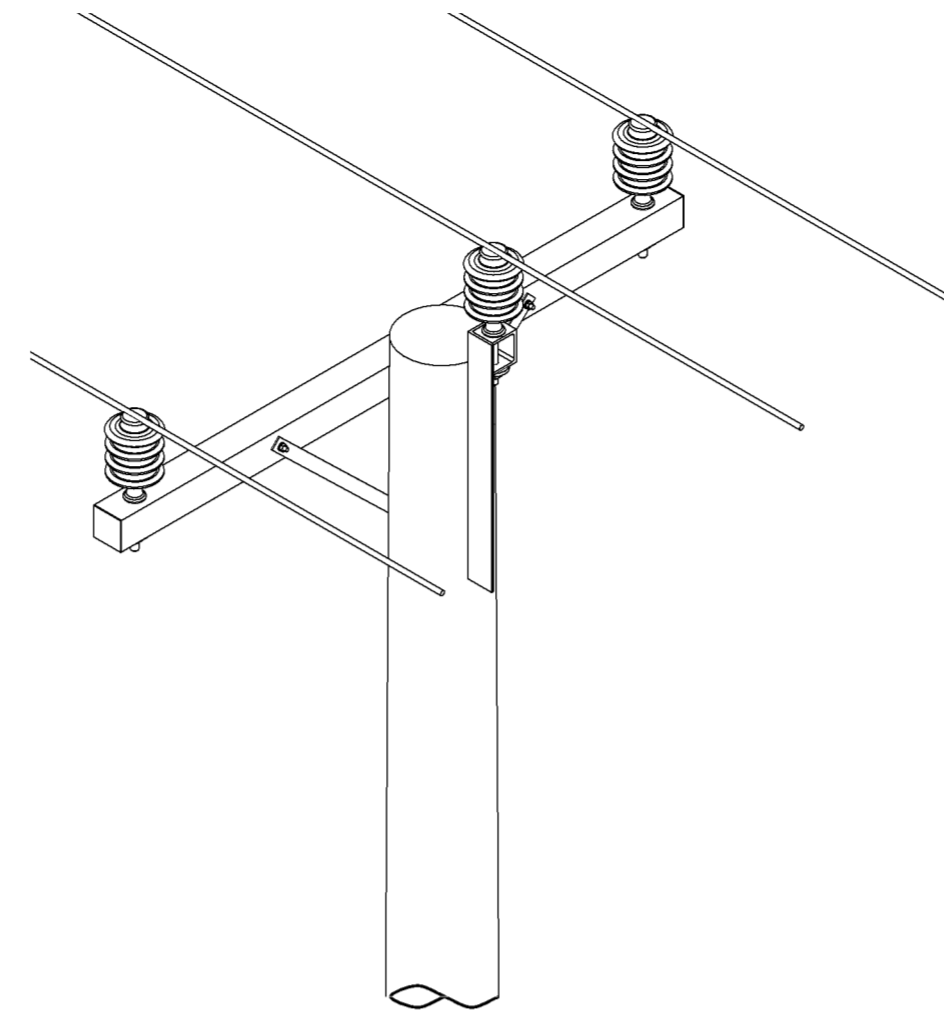
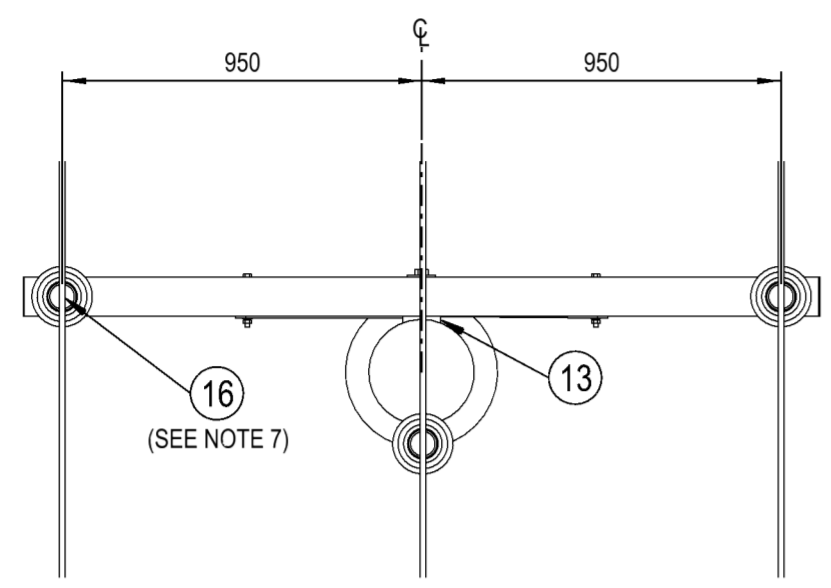

NOTES :

1. THE FOLLOWING INFORMATION IS OBTAINED FROM THE PROJECT DESIGN DRAWINGS:
 - a. POLE LENGTH AND STRENGTH.
 - b. SPECIAL FOUNDATION REQUIREMENTS.
 - c. POLE EMBEDMENT DEPTH.
 - d. CONDUCTOR SIZE.
 - e. VARIATIONS TO STANDARD CROSSARM REQUIREMENTS.
 - f. STAY REQUIREMENTS.
 - g. DEVIATION ANGLE.
2. THE MAXIMUM LINE DEVIATION ANGLE TO BE CONSTRUCTED ON THIS ARRANGEMENT IS TO BE DETERMINED BY THE LINE DESIGNER.
3. POLE STEPS ARE TO BE INSTALLED IN ACCORDANCE WITH THE REQUIREMENTS OF NS128.
4. IN AREAS WHERE THE 22kV NETWORK CANNOT BE WORKED ON USING LIVE LINE TECHNIQUES, UNDERBUILT CIRCUITS SHALL BE INSTALLED WITH A MINIMUM CLEARANCE OF 1200mm. IN AREAS WHERE THE 22kV NETWORK CAN BE WORKED ON USING LIVE LINE TECHNIQUES, UNDERBUILT CIRCUITS SHALL BE INSTALLED WITH A MINIMUM CLEARANCE OF 2500mm.
5. ALL BOLTS AND INSULATOR PINS PASSING THROUGH TIMBER ARE TO BE COATED WITH GRAPHITE GREASE.
6. POLES SHALL BE DRILLED, SCARFED AND DRESSED ON SITE. DRILLING AND SCARFING TO BE TREATED WITH APPROVED PRESERVATIVES.
7. IF THE CONDUCTOR DEVIATES AT THE INSULATOR, USE THE ANGLE TYPE CONDUCTOR TIE ARRANGEMENT, OTHERWISE USE THE INTERMEDIATE TYPE CONDUCTOR TIE ARRANGEMENT AS SHOWN ON DRG: 514038.
8. THIS IS THE PREFERRED CONSTRUCTION FOR ALL INTERMEDIATE STRUCTURES.
9. COMPOSITE FIBRE CROSSARMS ARE TO BE USED AS THE PREFERRED OPTION UNDER NORMAL CIRCUMSTANCES.
10. A 2106mm COMPOSITE FIBRE CROSSARM IS TO BE USED AS THE DEFAULT CROSSARM. A LONGER CROSSARM IS TO BE USED WHERE ADDITIONAL MID SPAN SEPARATION IS REQUIRED.
11. ONLY THE 2106mm COMPOSITE FIBRE CROSSARM OPTION IS SHOWN ON THIS CONSTRUCTION DRAWING. REFER TO DRGS: 262732, 514373 & 514374 FOR DRILLING PATTERN OF ALTERNATE CROSSARMS.
12. FOR DETAILS OF APPROVED ALTERNATE WAGNER COMPOSITE FIBRE CROSSARMS, REFER TO DRG: 265964.
13. REFER TO DESIGNER SAFETY REPORT D21/48279 FOR ATYPICAL HAZARDS ASSOCIATED WITH THIS STANDARD CONSTRUCTION.

ITEM	DESCRIPTION	DRG. No	STOCK CODE	QTY
17	STEP - POLE, SCREW-IN (SEE NOTE 3)	250144	185198	A/R
16	TIE - CONDUCTOR, HIGH VOLTAGE, SUPPORT ARRANGEMENT (SEE NOTE 7)	514038		4m
15	INSULATOR - 11/22kV AERODYNAMIC, (22/450) AND PIN ARRANGEMENT	513997		3
14	BRACKET - POLE TOP, GALVANISED	514380	H17314	1
13	BLOCK - GAIN, ALUMINIUM, 100mm		146274	1
12	WASHER - FLAT, M20, GALVANISED	518081	177986	1
11	WASHER - CONICAL, M20, GALVANISED	518082	H39655	1
10	WASHER - SQUARE, 75x75x6mm, GALVANISED (Ø22mm HOLE)	518081	H39231	1
9	BOLT & NUT - M20, HEX., GALVANISED (LENGTH TO SUIT POLE)	515466		1
8	WASHER - CONICAL, M12, GALVANISED	518082	H39639	1
7	WASHER - CONICAL, M12, GALVANISED (USE WITH HARDWOOD CROSSARMS)	518082	H39639	2
	WASHER - SPRING, M12, GALVANISED (USE WITH COMPOSITE FIBRE CROSSARMS)	518082	H12047	
6	WASHER - FLAT, M12, GALVANISED	518081	177982	5
5	BOLT & NUT - M12x130mm, HEX., GALVANISED	515466	46805	2
4	CROSSARM - 2700x100x100mm, TYPE B, HARDWOOD (SEE NOTES 9, 10, 11 & 12)	514373	H23884	1
	CROSSARM - 2100x100x100mm, TYPE C, HARDWOOD (SEE NOTES 9, 10, 11 & 12)	514374	H23834	
	CROSSARM - 3006x102x102mm, TYPE 10, COMPOSITE FIBRE (SEE NOTES 9, 10, 11 & 12)	262732	186780	
	CROSSARM - 2706x102x102mm, TYPE 9, COMPOSITE FIBRE (SEE NOTES 9, 10, 11 & 12)	262732	186779	
	CROSSARM - 2106x102x102mm, TYPE 7, COMPOSITE FIBRE (SEE NOTES 9, 10, 11 & 12)	262732	186777	
3	BOLT & NUT - M12, HEX., GALVANISED (LENGTH TO SUIT POLE)	515466		1
2	BRACE - CROSSARM, FLAT, 690mm, GALVANISED	514385	H17738	2
1	POLE - TIMBER (AS REQUIRED)	513988		1

ALL DIMENSIONS IN MILLIMETRES UNLESS NOTED OTHERWISE. DO NOT SCALE.

ITEM	DESCRIPTION	DRG. No
9	COMPOSITE FIBRE CROSSARMS WAGNER SPECIFICATION	265964
	2100mm CROSSARMS FOR LV, 11kV AND 33kV CONSTRUCTION DETAILS	514374
	SPECIAL CROSSARMS	514375
	2700mm CROSSARMS FOR LV, 11kV, 22kV AND 33kV CONSTRUCTION DETAILS	514373
	COMPOSITE FIBRE CROSSARMS SPECIFICATION	262732
	HV CONDUCTOR TIE SUPPORT ARRANGEMENTS	514038
ASSOCIATED DRAWINGS		

NETWORK STANDARD

 145 NEWCASTLE RD WALLSEND, NSW 2287

SCALE	1:20	STANDARD CONSTRUCTION		
DESIGNED	-	22kV SMALL DELTA CONSTRUCTION		
DRAWN	P.SAUNDERS	3-5		
CHECKED	P.A.S.			
APPROVED	R.BREMELL			
DATE	26/03/1996			
PROJECT NUMBER	STD			
PROJ/TRAK NUMBER	-	SIZE	DRAWING No	SHEET
		A2	513994	1
				AMD
				9